

WPE robbanásbiztos ventilátorok

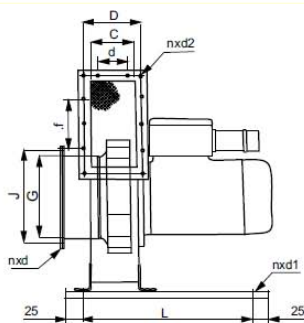
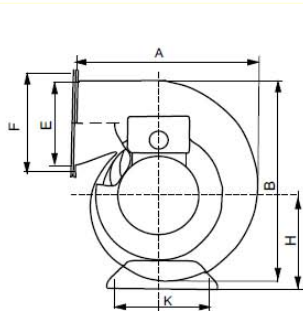

Typ	Wydajność Max	Wydajność nom. V		Spręż. nom.	Głośność*	Moc silnika	Ilość obrotów	Napięcie zasilania	Masa
	[m ³ /h]	[m ³ /s]	[m ³ /h]	[Pa]	[dB]	[kW]	[obr./min]	[V]	[kg]
WPE-14	740	0,11	400	230	65	0,18	2800	400	15
WPE-16	900	0,17	600	240	67	0,18	2820	400	18
WPE-18 M	810	0,12	432	84	64	0,18	1500	400	19
WPE-18 D	1520	0,24	868	327	69	0,25	2800	400	19
WPE-20 M	2200	0,31	1100	210	66	0,25	1500	400	33
WPE-20 D	4050	0,61	2200	800	70	1,50	2800	400	43
WPE-25 M	3250	0,50	1800	282	68	0,37	1500	400	57
WPE-25 S	6000	1,10	4000	415	81	1,10	1500	400	73
WPE-25 D	9300	1,00	3600	1050	72	2,20	2800	400	53
WPE-31 M	4500	0,75	2700	420	70	0,75	1500	400	64
WPE-31 D	9400	1,50	5400	1600	96	5,50	2800	400	113
WPE-35 M	8340	1,34	4824	365	72	1,50	1500	400	79
WPE-35 S	16000	2,63	9470	700	80	4,00	1500	400	145
WPE-35 D	16000	2,63	9470	1439	99	7,50	2800	400	135
WPE-40 M	7900	1,52	5470	960	78	3,00	1500	400	105
WPE-40 S	12600	1,82	6580	300	78	1,50	900	400	123
WPE-40 D	22200	3,10	11200	860	93	4,00	1500	400	137
WPE-45 M	17800	2,70	10000	550	88	2,20	900	400	-
WPE-45 D	28000	7,70	18000	1100	95	7,50	1500	400	-
WPE-50	24700	3,72	13400	720	87	5,5	900	400	-

Typ	Wymiary															
	A	B	C	D	E	F	G	J	K	L	d	f	H	n x d2	n x d	n x d1
	[mm]	[mm]	[mm]	[mm]	[mm]	[mm]	[mm]	[mm]	[mm]	[mm]	[mm]	[mm]	[mm]			
WPE-14	284	300	125	149	100	124	140	164	180	185	-	-	155	4x7	8x7	2x7
WPE-16	350	390	125	149	180	204	160	184	200	185	-	140	185	8x7	8x7	2x7
WPE-18	425	465	140	164	200	224	182	204	250	200	-	140	240	8x7	8x7	2x10
WPE-20	525	590	160	192	250	282	200	224	350	220	-	140	290	8x10	8x7	2x12
WPE-25	653	726	200	232	315	347	250	274	400	260	140	140	345	12x10	8x7	2x12
WPE-31	750	800	250	282	315	347	315	339	400	310	140	140	380	12x10	8x7	2x12
WPE-35	815	899	315	347	355	387	355	387	550	310	140	140	420	12x10	12x10	2x12
WPE-40 M.	860	948	250	312	400	432	400	432	500	340	140	140	440	12x10	12x10	2x12
WPE-40SD	990	1140	400	432	450	482	400	432	650	900	140	140	500	12x10	12x10	2x14
WPE-45	1170	1340	400	432	500	463	450	482	750	1100	140	140	590	12x10	12x10	2x14
WPE-50	1349	1550	450	482	630	662	500	573	655	950	140	140	695	20x10	16x15	2x14

Charakterystyka aerodynamiczna "WPE-14,16"

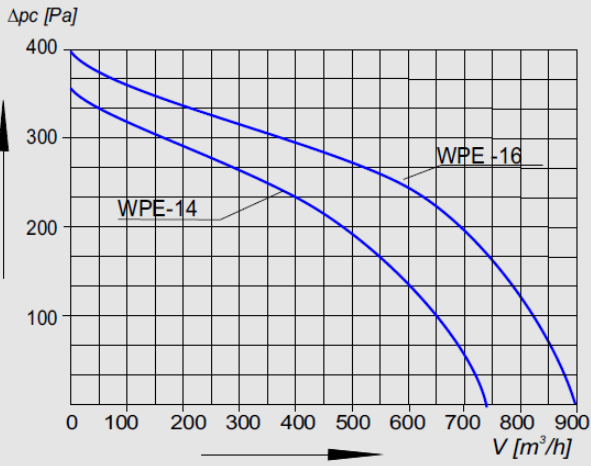

Charakterystyka aerodynamiczna WPE -18

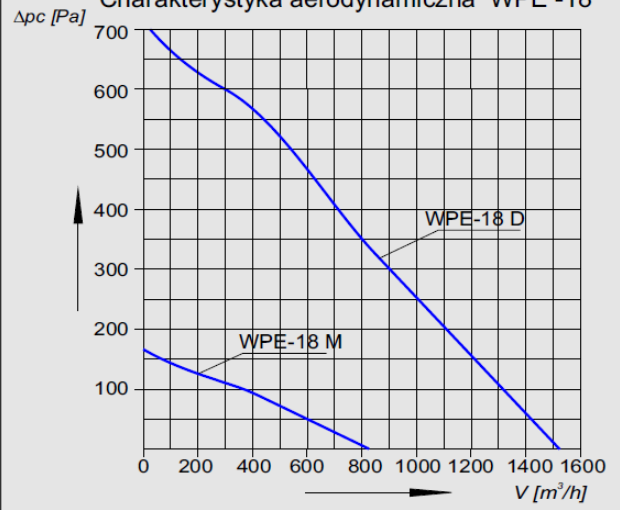

Charakterystyka aerodynamiczna WPE-20

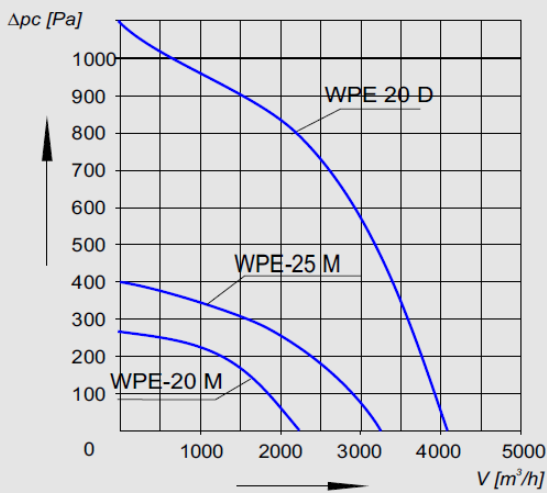

Charakterystyka aerodynamiczna WPE-25,31

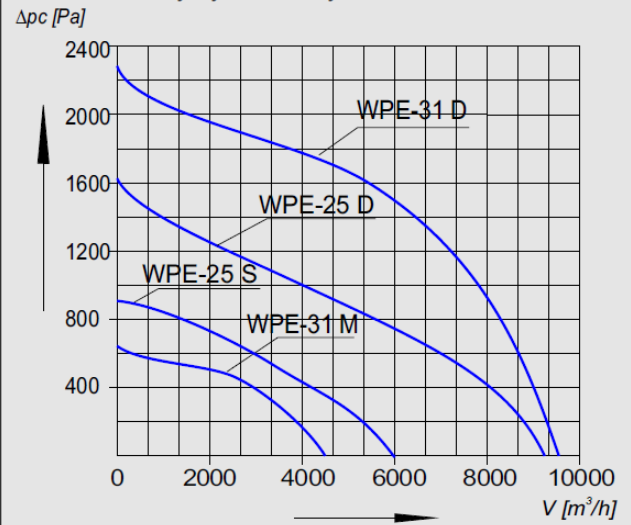

Charakterystyka aerodynamiczna WPE-35

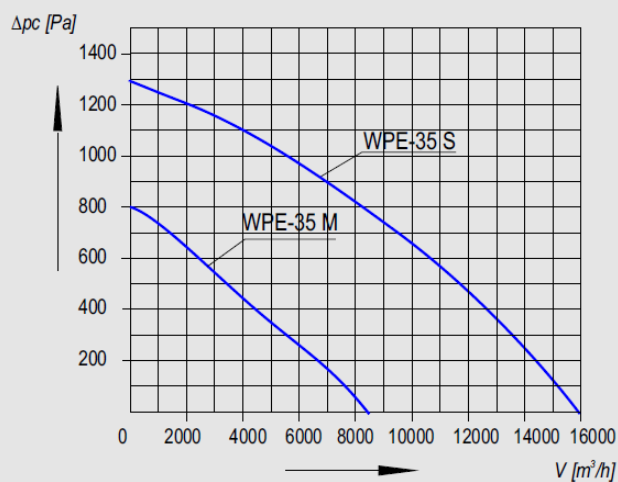

Charakterystyka aerodynamiczna WPE-35 D

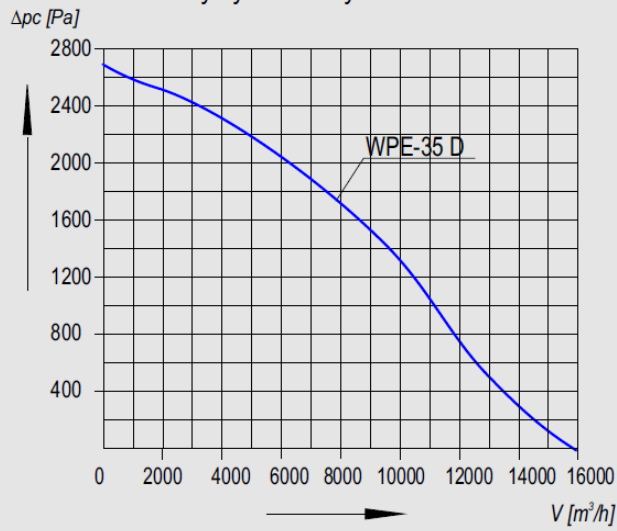

Charakterystyka aerodynamiczna WPE- 40 M

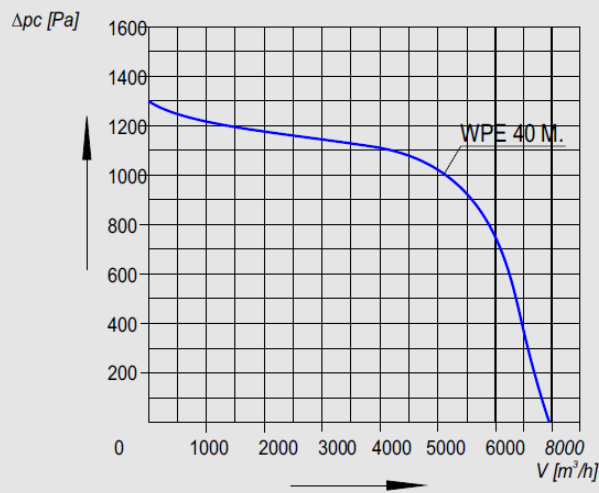

Charakterystyka aerodynamiczna "WPE-40"

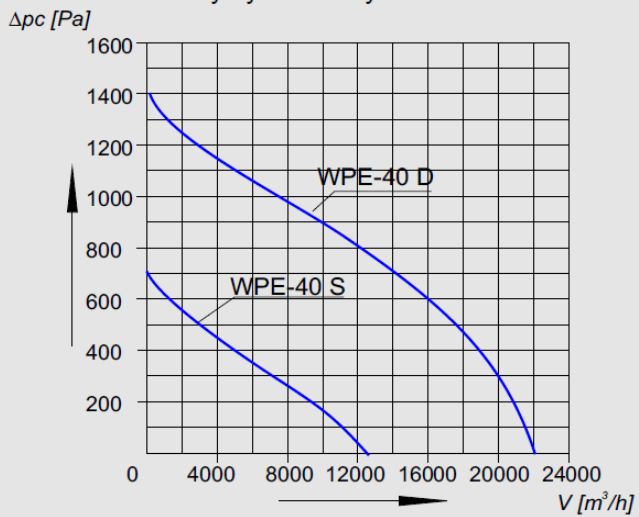

Charakterystyka aerodynamiczna "WPE-45, WPE-50"

